

Kato NK-250E-III

Dimensions

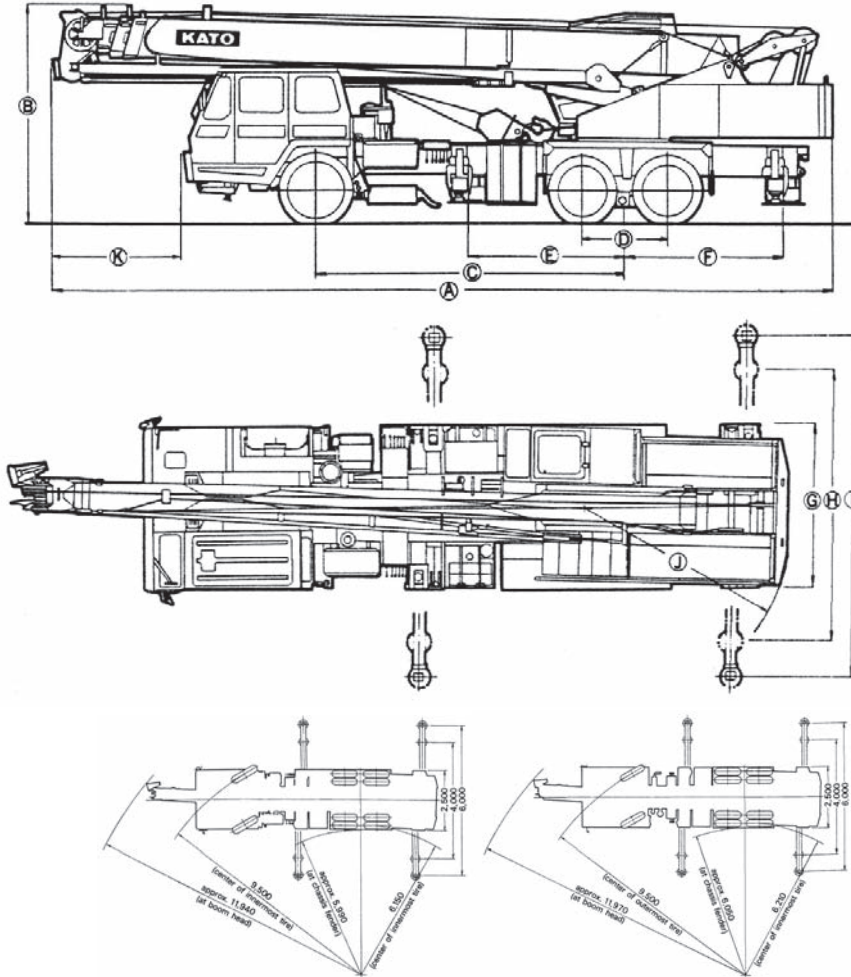

25
Tonne

Truck Mounted
Cranes

Hookblock

Mitsubishi K203LA

Nissan Diesel KW30MXL

Capacity (t)	25	3
Weight (t)	0.28	0.06

Carrier name and model	A	B	C	D	E	F	G	H	I	J	K
Mitsubishi K203BLA	11,930	3,300	4,700	1,300	2,400	2,200	2,500	4,000	6,000	3,215	2,100
Nissan Diesel KW30MXL	11,930	3,300	4,600	1,300	2,450	2,450	2,500	4,000	6,000	3,215	1,950

(Unit: mm)

The charts that have been included have been reproduced from manufacturer specifications, and while every effort has been made to ensure their accuracy, we do not accept any responsibility for errors or omissions. We also need to draw your attention to the guidance notes on page 47 to assist you with your crane selection.

Kato NK-250E-III

Main Boom Duties

Working Radius (m)	With fully extended outriggers - over side and over rear						
	10m Boom	13.5m Boom	17m Boom	20.5m Boom	24m Boom	27.5m Boom	31m Boom
2.5	25	17.5	14.5				
3	25	17.5	14.5	9.5			
3.5	20.6	17.5	14.5	9.5	7.5		
4	18	17.5	14.5	9.5	7.5	6.5	
4.5	16.3	15.8	14.5	9.5	7.5	6.5	
5	14.85	14.4	13.25	9.5	7.5	6.5	6
5.5	13.65	13.25	12.2	9.5	7.5	6.5	6
6	12.3	12.2	11.3	9.5	7.5	6.5	6
6.5	11.2	11	10.5	9.5	7.5	6.5	6
7	10.25	10	9.8	8.8	7.5	6.5	6
7.5	9.4	9.2	9.1	8.3	7.5	6.5	6
8	8.65	8.45	8.35	7.8	7	6.1	5.65
8.3	8.25	8.05	7.95	7.5	6.75	5.9	5.45
9		7.2	7.1	6.95	6.25	5.45	5.05
9.5		6.65	6.5	6.55	5.9	5.2	4.8
10		6	5.9	6.2	5.6	4.95	4.6
11		5	4.85	5.25	5	4.5	4.2
11.8		4.3	4.2	4.6	4.65	4.15	3.95
12			4.1	4.45	4.6	4.1	3.9
14			2.9	3.25	3.4	3.5	3.35
15.3			2.3	2.7	2.85	3	3
16				2.4	2.6	2.75	2.85
18				1.75	1.95	2.1	2.15
18.8				1.5	1.75	1.9	1.95
20					1.45	1.6	1.7
22					1.1	1.2	1.3
22.3					1	1.15	1.25
24						0.9	0.95
25.8						0.65	0.75
28							0.5
29.3							0.4

The charts that have been included have been reproduced from manufacturer specifications, and while every effort has been made to ensure their accuracy, we do not accept any responsibility for errors or omissions. We also need to draw your attention to the guidance notes on page 47 to assist you with your crane selection.

25
Tonne

Truck Mounted
Cranes

TM2

Kato NK-250E-III

Main Boom Duties

Working Radius (m)	With intermediately extended outriggers - 360° full range						
	With fully extended outriggers - over front						
	10m	13.5m	17m	20.5m	24m	27.5m	31m
	Boom	Boom	Boom	Boom	Boom	Boom	Boom
2.5	20	17.5	14.5				
3	20	17.5	14.5	9.5			
3.5	20	17.5	14.5	9.5	7.5		
4	16.5	17.5	14.5	9.5	7.5	6.5	
4.3	14.4	14.85	14.5	9.5	7.5	6.5	
5	10.5	10.5	10.2	9.5	7.5	6.5	6
5.7	7.9	7.8	7.6	7.4	7.5	6.5	6
6	7.1	7	6.8	6.8	7	6.5	6
6.5	6	5.9	5.65	5.85	6.15	6.5	6
6.6	5.85	5.7	5.45	5.7	6	6.3	6
7	5.2	5	4.8	5.1	5.35	5.6	5.5
8.3	3.6	3.4	3.2	3.6	3.38	4	4.1
9		2.8	2.65	3	3.25	3.4	3.5
10		2.1	1.95	2.3	2.55	2.75	2.8
11		1.5	1.35	1.75	2	2.2	2.3
11.8		1.15	1.05	1.4	1.65	1.85	1.9
13			0.65	0.95	1.2	1.35	1.5
13.5			0.5	0.8	1.05	1.2	1.3
14.5				0.5	0.8	0.9	1.05
15					0.7	0.8	0.9
16					0.45	0.55	0.7
16.5						0.45	0.6
17.5							0.4



25
Tonne

Truck Mounted
Cranes



The charts that have been included have been reproduced from manufacturer specifications, and while every effort has been made to ensure their accuracy, we do not accept any responsibility for errors or omissions. We also need to draw your attention to the guidance notes on page 47 to assist you with your crane selection.

Kato NK-250E-III

Fly Jib Duties

25
Tonne

Truck Mounted
Cranes

Boom Angle (°)	With fully extended outriggers - Over side and over rear					
	31m boom + 8m jib					
	Offset 5°		Offset 17°		Offset 30°	
	Working Radius (m)	Load (t)	Working Radius (m)	Load (t)	Working Radius (m)	Load (t)
80	8	2.75	8.8	1.95	10.2	1.35
76	10.5	2.75	11.5	1.95	13	1.35
75.5	11	2.65	12	1.9	13.5	1.35
70	14.6	2.07	15.7	1.53	16.8	1.15
65	17.7	1.73	18.8	1.32	19.6	1.02
60	20.6	1.5	21.7	1.15	22.3	0.9
54	23.8	1.28	24.8	1	25.4	0.8
50	25.7	0.94	26.6	0.9	27.3	0.75
48.5	26.4	0.84	27.3	0.8	27.9	0.73
44	28.3	0.62	29.1	0.6	29.8	0.58
40	30	0.48	30.6	0.45	31.2	0.44

Boom Angle (°)	With intermediately extended outriggers - 360° full range With fully extended outriggers - over front					
	31m boom + 8m jib					
	Offset 5°		Offset 17°		Offset 30°	
	Working Radius (m)	Load (t)	Working Radius (m)	Load (t)	Working Radius (m)	Load (t)
80	8	2.75	8.8	1.95	10.2	1.35
76	10.5	2.75	11.5	1.95	13	1.35
75.5	10.8	2.6	11.8	1.9	13.5	1.35
72	12.9	1.77	14	1.6	15.6	1.15
70	14	1.45	15.3	1.28	16.7	1.07
65	16.9	0.75	18.2	0.67	19.5	0.58
61	19.1	0.35	20.3	0.32	21.5	0.3

The charts that have been included have been reproduced from manufacturer specifications, and while every effort has been made to ensure their accuracy, we do not accept any responsibility for errors or omissions. We also need to draw your attention to the guidance notes on page 47 to assist you with your crane selection.